



# Maximize Your Battery Storage and Shipping

## Max Case CBSTC085

The premier solution for preventing and containing hazardous battery fires. The CellBlock® Max Case is capable of accommodating large-format batteries and offers the absolute maximum protection against lithium-ion thermal events with 360° suppression coverage for all of its contents.

Each case is double-lined with .125 inch steel and CellBlock's proprietary fire panels. The pressure relief system mitigates smoke and fumes and eliminates risk of explosion due to overpressurization.

- ✓ Patented FCP Technology
- ✓ CellBlockEX® Deployment
- ✓ Gas Mitigation
- ✓ Fork Lift Glides
- ✓ Removable Bumpers
- ✓ Safety Placards
- ✓ Adjustable Battery Support Tray
- ✓ Special Permit 20549
- ✓ UN Rated
- ✓ P911/LP906 Tested and Certified

call 1300 32 62 92

**CellBlock**  
Fire Containment Systems

  
**eco batt**  
safety

# Max Case CBSTC085

## Specifications

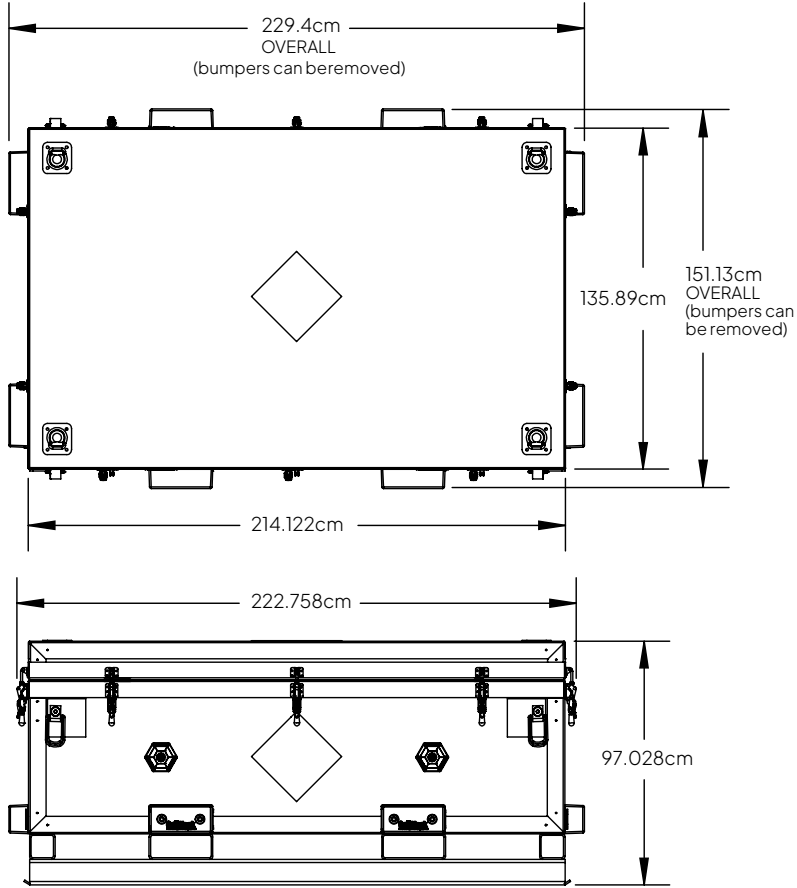

<b>UN Mark</b>	50A/X/S/**/USA/ M6484/4716/2434 ** month/year of manufacture
<b>Exterior Dimensions</b>	229.4cm x 151.1cm x 48.3cm
<b>Interior Dimensions</b>	193cm x 116.8cm x 48.3cm
<b>Weight</b>	1361 kg
<b>Max. Content Weight</b>	1073 kg max.
<b>Gross Weight Limit</b>	2434 kg max.

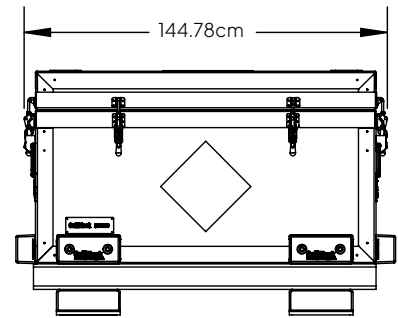

### Tested beyond compliance

We subject our cases to “worst-case scenario” testing.



### Effective suppression

With a self-deployed extinguishing system featuring CellBlockEX® Technology.

Ecobatt Safety makes no representations or warranties of any kind, express or implied, about the completeness, accuracy, reliability, sustainability, suitability or availability with respect to these products and procedures for any purpose. In no event will Ecobatt Safety be liable for any loss or damage including without limitation, indirect or consequential loss or damage, or any damage whatsoever arising from the usage of these products.

call 1300 32 62 92

[ecobattsafety.com.au](http://ecobattsafety.com.au)

